

**창일정공(주)**  
CHANG IL MACHINERY, LTD

대표이사 **이병민**

주소: 부산광역시 부산진구 부전동 474-80  
유원O/T 1419호  
전화: 051 807 4825 FAX: 051 807 4826  
핸드폰: 010 3075 3948  
E-mail: cimco21@naver.com  
<https://cimcotool.modoo.at/>



# SOLID CUTTER

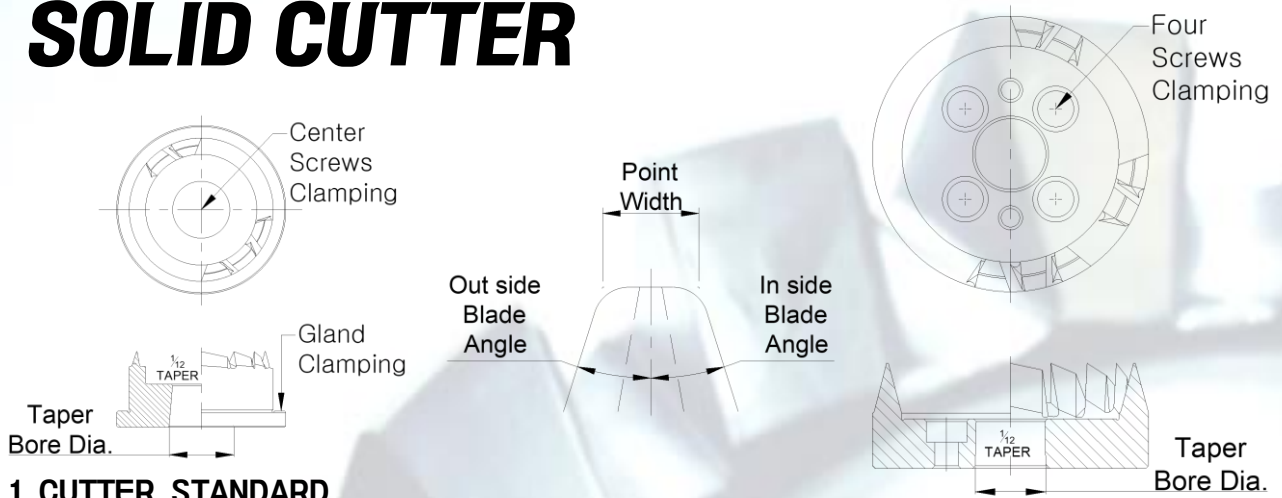

## 1. CUTTER STANDARD

Cutter Name	Average Cutter Dia.	Number of Blades					Standard Specification		Clamping Style
		4	8	12	16	20	Cutter Number	Cutting Depth	
Solid Cutter	0.7"~1.0"	○					#-12~#35	3.5mm	Gland
	1.1"	○	○					3.5mm	Gland
	1.3"~1.5"	○	○	○				3.5~5.0mm	Gland
	2.0"		○	○				5.0mm	Gland
	2.5"		○	○				7.0mm	Center Screw
	2.6"~2.75"		○	○	○			7.0~10.0mm	Four Screws
	3.0"		○	○	○			10.0~12.0mm	Four Screws
	3.5"			○	○	○		10.0~14.0mm	Four Screws
	4.5"			○	○	○		10.0~16.0mm	Four Screws

## 2. FOB Busan Port Price (US\$)

0.7"~1.0"	280.00
1.1"	320.00
1.3"~1.5"	340.00
2.0"	370.00
2.5"	380.00
2.6"~2.75"	410.00
3.0"~3.5"	840.00
4.5"	1,140.00

\* Excluding TiN Coating Cost

## 3. Method of Ordering Cutters

Information	Mark existing or new standards as follows:
	<ol style="list-style-type: none"> <li>If existing standard: <ul style="list-style-type: none"> <li>Mark as previously provided tool number.</li> </ul> </li> <li>If new standard: Mark as 'NEW' and provide End-user requested specifications below. <ul style="list-style-type: none"> <li>Average Diameter(AVE.DIA.):</li> <li>Point Width(PW.):</li> <li>Cutter Number(CTT.No.):</li> <li>Number of Blades(BLD.No.):</li> <li>Hand(RH or LH):</li> <li>Toprem Letter(TPR.): (Omit if no Toprem request)</li> <li>Quantity(Q'ty):</li> </ul> </li> </ol>

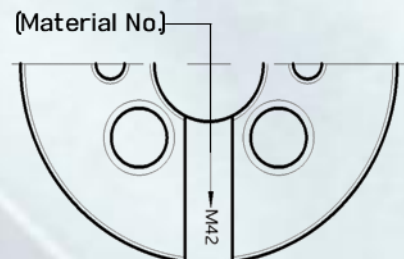
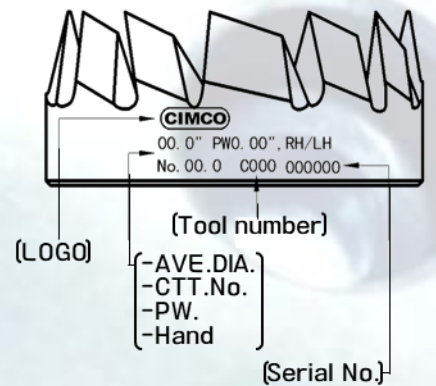

# ROU.&FIN. OLD CUTTER

Soft Body Cutter of GREASON

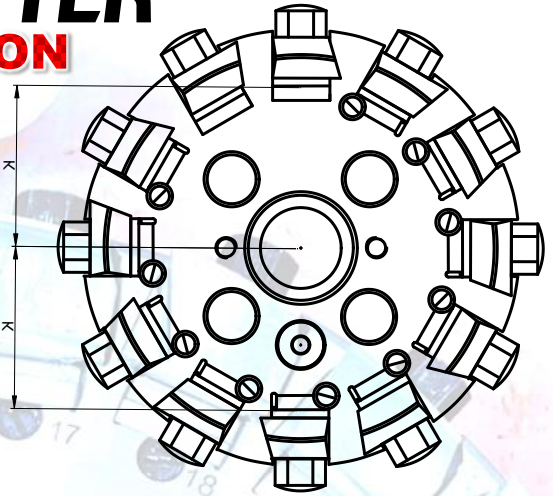
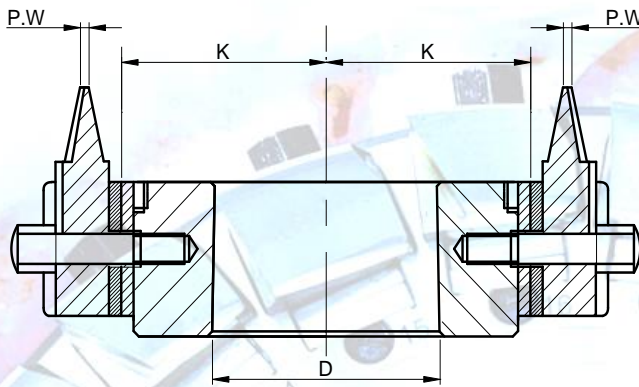

## 1. CUTTER STANDARD

No.	Average Cutter Dia.	Processing	Head Number			Number of Blade		Cutting Depth	Clamping Style
			Series	Alter-nate	Single Side	Master Alt. / Sing.	Blades		
1	3.0"	ROU.&FIN.	30 200 -	001	-	2 / -	8	9.0mm	Center Screw
		ROUGHING	-	-	-	-	-		
2	3.5"	ROU.&FIN.	30 200 -	001	-	2 / -	8	9.0mm	Center Screw
		ROUGHING	-	-	-	-	-		
3	4.5"	ROU.&FIN.	30 200 -	002	-	2 / -	8	9.5~15.0mm	Four Screws
		ROUGHING	-	-	-	-	-		
4	6.0"	ROU.&FIN.	30 200 -	004	018	2 / (1)	12	9.5~15.0mm	Four Screws
		ROUGHING	30 201 -	001	-	2 / -	16		
5	7.5"	ROU.&FIN.	30 200 -	005	023	2 / (1)	12	13.0~18.0mm	Four Screws
		ROUGHING	30 201 -	002	-	2 / -	20		
6	9.0"	ROU.&FIN.	30 200 -	007	028	2 / (1)	16	14.0~18.0mm	Four Screws
		ROUGHING	30 201 -	003	-	2 / -	24		
7	12.0"	ROU.&FIN.	30 200 -	009	033	2 / (1)	20	20.0mm	Four Screws
		ROUGHING	30 201 -	008	-	2 / -	32		
8	14.0"	ROU.&FIN.	30 200 -	010	036	2 / (1)	24	20.0mm	Four Screws
		ROUGHING	30 201 -	013	-	2 / -	-		
9	15.0"	ROUGHING	30 200 -	-	037	- / (1)	24	20.0mm	Four Screws
10	16.0"	ROU.&FIN.	30 200 -	012	-	2 / -	24	20.0mm	Four Screws
		ROUGHING	30 201 -	013	-	2 / -	40		
11	18.0"	ROU.&FIN.	30 200 -	015	047	2 / (1)	24	25.4mm	Four Screws
		ROU.&FIN.	30 200 -	016	-	2 / -	28		

## 2. FOB Busan Port Price (US\$)

SIZE	FULL SET	BLADES
3.0"~4.5"	370.00	140.00
6.0"	530.00	200.00
7.5"	650.00	280.00
9.0"	870.00	540.00
12.0"	1,240.00	630.00
14.0"	1,800.00	830.00
16.0"	2,040.00	900.00
18.0"	2,040.00	900.00

\* Excluding TiN Coating Cost

\* FULLSET:

HEAD SET+PARALLEL SET+B:ADES

CIMCO CHANG IL MACHINERY CO.,LTD

## 3. Method of Ordering Cutters

Mark existing or new standards as follows:

- If existing standard:
  - Mark as previously provided tool number.
- If new standard: Mark as 'NEW' and provide End-user requested specifications below.
  - HEAD Number(HEAD No.):
  - Average Diameter(AVE.DIA.):
  - Point Width(PW.):
  - Cutter Number(CTT.No.):
  - Number of Blades(BLD.No.):
  - Hand(RH or LH):
  - Toprem Letter(TPR.):
  - Quantity(Q'ty):

Information



# FIN.&COM. NEW CUTTER

## HARD-AC II & HARD-AC III Cutter

### of GREASON.

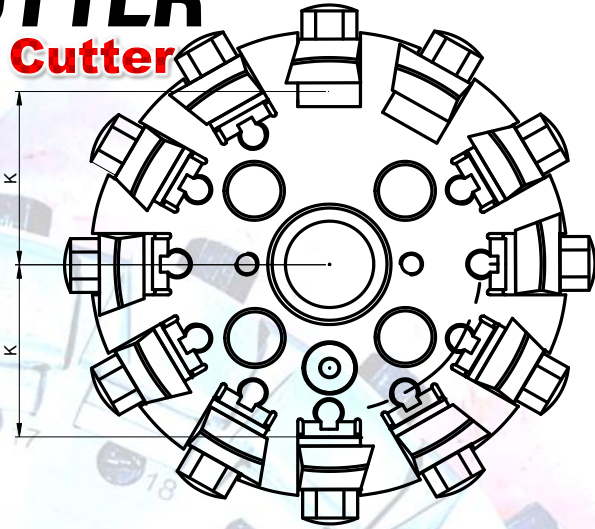
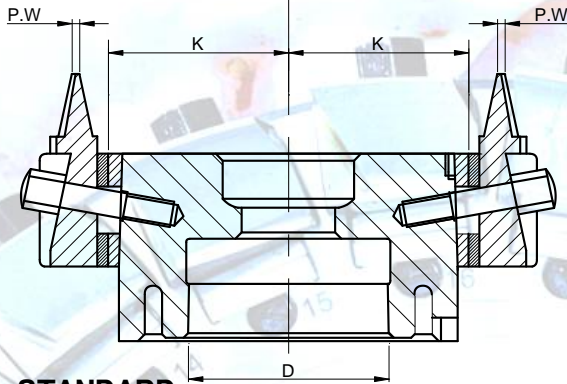

### 1. CUTTER STANDARD

No.	Average Cutter Dia.	Processing	HEAD Number (Alternate)	Number of Blades	Cutting Depth	Clamping Style
1	5.0"	Finishing	30 212 001	12	≒ 10.0mm	Center screw
		Completing	30 233 002	12	≒ 10.0mm	
2	6.0"	Finishing	30 212 002	12	≒ 10.0mm	Center or Four screws
		Completing	30 212 003 30 233 004	16 14	≒ 10.0mm ≒ 13.0mm	
3	7.5"	Finishing	30 212 005	16	≒ 13.0mm	Four screws
		Completing	30 233 006	18	≒ 15.0mm	
4	9.0"	Finishing	30 212 006	12	≒ 17.0mm	Four screws
		Completing	30 212 008 30 233 008	20 22	≒ 14.0mm ≒ 18.0mm	
5	10.5"	Finishing	30 233 010	26	≒ 20.0mm	Four screws
		Completing			≒ 20.0mm	
6	12.0"	Finishing	30 212 009	12	≒ 20.0mm	Four screws
		Completing	30 233 012	28	≒ 20.0mm	

### 2. FOB Busan Port Price (US\$)

SIZE	FULL SET	BLADES
3.0"~4.5"	370.00	140.00
6.0"	530.00	200.00
7.5"	650.00	280.00
9.0"	870.00	540.00
12.0"	1,240.00	630.00
14.0"	1,800.00	830.00
16.0"	2,040.00	900.00
18.0"	2,040.00	900.00

\* Excluding TiN Coating Cost

\* FULLSET:

HEAD SET+PARALLEL SET+BLADES

### 3. Method of Ordering Cutters

Information	Mark existing or new standards as follows:
	<ol style="list-style-type: none"> <li>If existing standard: <ul style="list-style-type: none"> <li>- Mark as previously provided tool number.</li> </ul> </li> <li>If new standard: Mark as 'NEW' and provide End-user requested specifications below. <ul style="list-style-type: none"> <li>- HEAD Number(HEAD No.):</li> <li>- Average Diameter(AVE.DIA.):</li> <li>- Point Width(PW.):</li> <li>- Cutter Number(CTT.No.):</li> <li>- Number of Blades(BLD.No.):</li> <li>- Hand(RH or LH):</li> <li>- Toprem Letter(TPR.):</li> <li>- Quantity(Q'ty):</li> </ul> </li> </ol>





# JCMT BEVEL GEAR GENERATOR

5-axis machine with 4-axis linkage

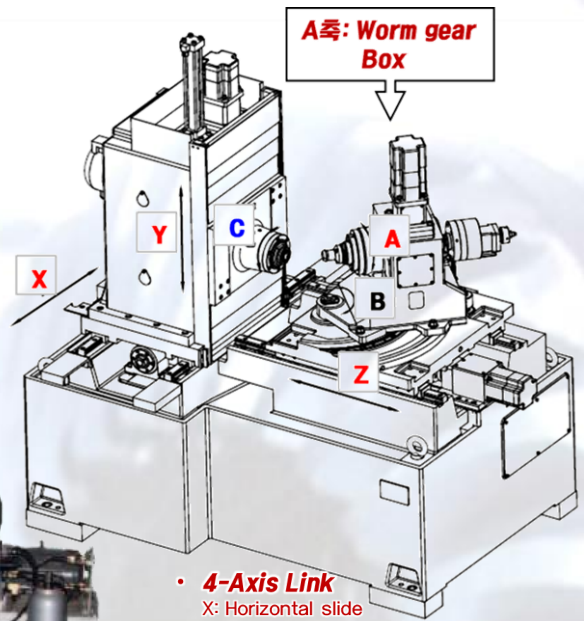

• **4-Axis Link**

- X: Horizontal slide
- Y: Vertical slide
- Z: Sliding base
- A: Work spindle
- B: Machine root angle
- C: Cutter spindle

• **Tooth Cutting Method**

- ◆ **Spiral bevel gear**
- **Face milling**
- ▷ **Wet Cut**
- **Generating with DDSG Cal.Program**
- **5-cutting with SSM Cal.Program**

SPECIFICATIONS	YH603B 7.4	YH603H 7.7	YH604 14.2	YH605 18.7	Applicable cutter type
CNC System	Siemens 828Dsl	Siemens 828Dsl	Siemens 828Dsl	Siemens 828Dsl	■ Gleason-style Soft Body series cutter and Hard-ac series cutter
Max. module (mm)	4	6	10	15	■ Application method
Max. transmission ratio	10:01	10:01	10:01	10:01	1. Implemented with GENERATING Method (Simultaneous rough and finish machining)
Max. face width (mm)		50	58	85	▷ Pinion: Alternate Cutter
Number of teeth 5~100	5~100	5~200	5~200	5~200	▷ Gear: Alternate Cutter
Max. diameter of workpiece (mm)	200	320	400	600	2. Implemented with a Five-Cutting Method
Cutter diameter	2~6 inch	3.5~7.5 inch	5~12 inch	7.5~16 inch	▷ Pinion:
Cutter spindle speed (RPM)	100~350	50~200	30~150	30~75	1) Roughing:
Workpiece spindle taper	Morse 5#	1:20	1:20	1:20	Alternate Cutter
Hole diameter of the larger end (mm)	44.399	70	100	153	2) Finishing:
Workpiece spindle speed (r/min)	0-30	0-30	0-40	0-40	- Concave:
Overall dimensions : L×W×H(mm)	2150×1950×2325	2200×1950×2325	2380×1990×2503	2900×2400×3120	Single side Cutter
Total weight (Kg)	4200	6000	8000	12000	- Convex:
					Single side Cutter
					▷ Gear:
					1) Roughing:
					Alternate Cutter
					2) Finishing:
					Alternate Cutter

# JCMT BEVEL GEAR GENERATOR

6-axis machine with 5-axis linkage

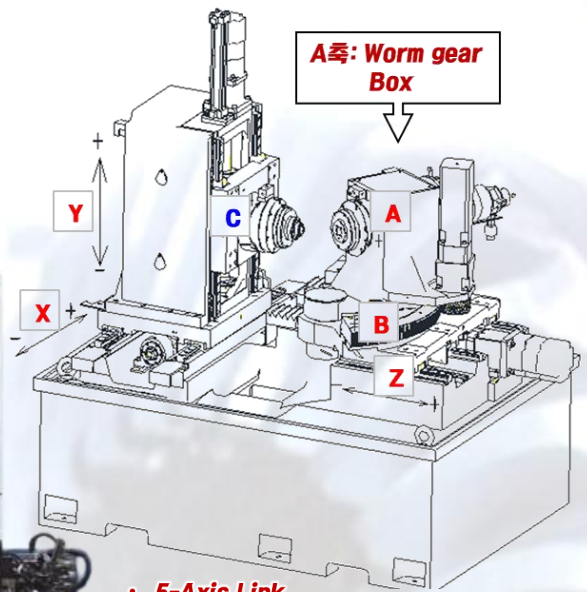

• **5-Axis Link**

- X: Horizontal slide
- Y: Vertical slide
- Z: Sliding base
- A: Work spindle
- B: Machine root angle
- C: Cutter spindle

• **Tooth Cutting Method**

◆ **Spiral bevel gear**

- **Face milling**
  - ▷ **Wet Cut**
    - Generating with **DDSG Cal.Program**
    - Compatible with **Greason Cal.Program**

SPECIFICATIONS	JCB12 B13.7-W30.7	JCB20 15.2	JCB32 17.7	JCB40 24.2	Applicable cutter type & Tooth cutting Method
CNC System	Siemens 840Dsl	Siemens 840Dsl	Siemens 840Dsl	Siemens 840Dsl	■ Gleason-style Soft Body series cutter and Hard-ac series cutter
Max. module (mm)	2.5	4	6	10	■ Application method
Max. transmission ratio	10:01	10:01	10:01	10:01	1. Implemented with Completing Method
Max. face width (mm)	20	30	50	58	▷ Pinion: Free-Mode (duplex double roll)
Number of teeth 5~100	5~200	5~200	5~200	5~200	▷ Gear: G-Mode (Forming)
Max. diameter of workpiece (mm)	125	200	320	400	2. Implemented with Generating Method (Simultaneous rough and finish machining)
Cutter diameter	1.5~3.5 inch	2~6 inch	2.5~7.5 inch	5~12 inch	▷ Pinion: G-Mode (Generating)
Cutter spindle speed (RPM)	100~1000	100~500	120~350	200	▷ Gear: G or GG-Mode (Generating)
Workpiece spindle taper	Morse 5#	Morse 5#	1:20	1:20	※ GG-Mode
Hole diameter of the larger end (mm)	31.267	44.399	70	100	1. High-performance gear tooth profiles are required: G1-Concave + G2-Convex
Workpiece spindle speed (r/min)	0-30	0-30	0-30	0-160	2. High-quality roughness effect is required: G1-Roughing + G2-Finishing
Overall dimensions : L×W×H (mm)	2400×2300×2100	3500×2200×2300	4400×2500×2600	4685×2876×2600	
Total weight (Kg)	3,000	6,500	7,500	9,000	





# JCMT BEVEL GEAR GENERATOR

6-axis machine with 6-axis linkage

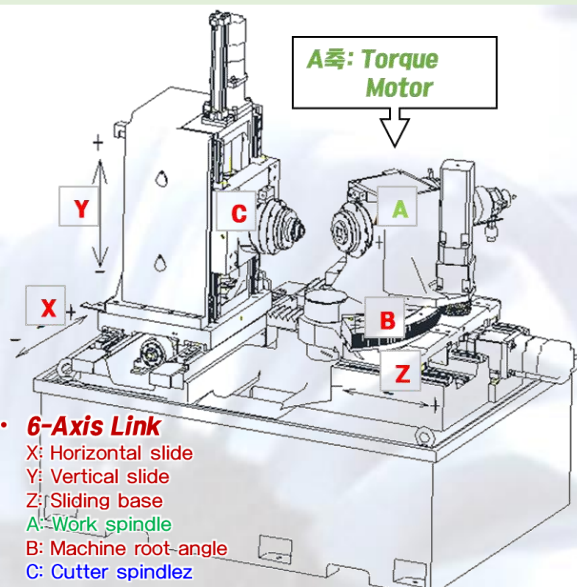

## 6-Axis Link

- X: Horizontal slide
- Y: Vertical slide
- Z: Sliding base
- A: Work spindle
- B: Machine root-angle
- C: Cutter spindle

## Tooth Cutting Method

### ◆ Spiral bevel gear

- Face milling
  - ▷ Wet Cut & Dry Cut
    - Generating with DDSG Cal.Program
    - Compatible with Greason Cal.Program
- Face hobbing
  - ▷ Wet Cut
    - Compatible with Greason Cal.Program

### ◆ Straight bevel gear

- Face milling
  - ▷ Wet Cut
    - Upper and Lower Completing

SPECIFICATIONS	JCB12b	JCB20a	JCB32a	JCB40a	Applicable cutter type & Tooth cutting Method
CNC System	Bosch Rexroth MTX micro control 2 Independent CNC Controls	Bosch Rexroth MTX micro control 2 Independent CNC Controls	Bosch Rexroth MTX micro control 2 Independent CNC Controls	Bosch Rexroth MTX micro control 2 Independent CNC Controls	■ Application method
Max. module (mm)	2.5	4	6	10	1. Spiral bevel Gear
Max. transmission ratio	10:01	1:10	1:10	1:10	◆ Completing Method (G-mode & Free-mode)
Max. face width (mm)	20	30	50	58	◆ Generating Method (G-mode or GG-mode)
Number of teeth 5~100	5~200	5~200	5~200	5~200	▶ Cutter: 1) Wet Cutting: Gleason-style Hard-ac cutter
Max. diameter of workpiece (mm)	125	200	320	400	2) Dry Cutting: Special carbide cutter
Cutter diameter	1.5~3.5 inch	1.5~6 inch	2.5~7.5 inch	5~12 inch	2. Stright bevel Gear
Cutter spindle speed (RPM)	100~1000	500~1500	200~1200	200~950	◆ Up-Low Position Method (Free-mode)
Workpiece spindle taper	Morse 5#	Morse 5#	1:20	1:20	▶ Cutter: 1) Wet Cutting: Special cutter resembling Gleason Coniflex style
Hole diameter of the larger end (mm)	31.267	44.399	70	100	
Workpiece spindle speed (r/min)	0-30	600	300	300	
Overall dimensions : L×W×H (mm)	2400×2300×2100	3300×3700×2300	4400×2500×2600	4685×2800×2600	
Total weight (Kg)	3,000	6,500	6,700	10,000	

# JCMT BEVEL GEAR GRINDING MACHINE

7-axis machine with 6-axis linkage

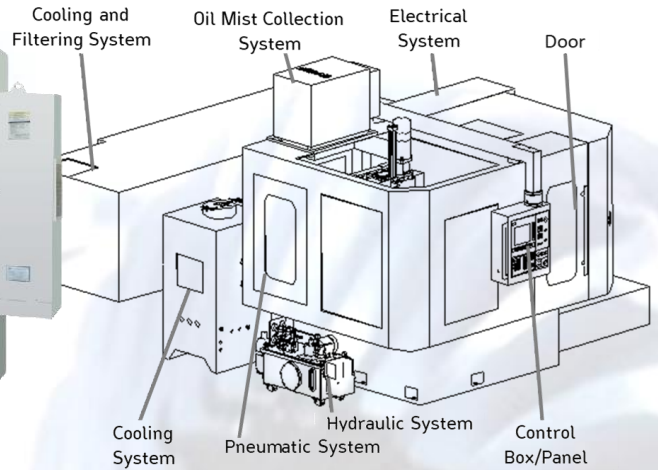

### ► 7-Axis Coordinate definition :

- X : The grinding wheel spindle moves forward and backward  
연삭 휠 스펀들이 앞뒤로 수평이동.
- Y : The grinding wheel spindle rises and falls vertically.  
연삭 휠 스펀들이 상하로 수직이동.
- Z : The grinding wheel spindle moves forward and backward in the left and right directions.  
연삭 휠 스펀들이 좌우 방향으로 수평이동.
- A : The workpiece spindle rotates.  
공작물 스펀들이 회전.
- B : The gear installation angle rotates.  
기어 설치 각도가 회전.
- C : The grinding wheel spindle rotates.  
연삭 휠 스펀들이 회전.
- D : The grinding wheel dresser rotates.  
연삭 휠 드레서가 회전.



SPECIFICATIONS	JCB20MP 37.3	JCB35MP 48.2	Applicable method & Other options
CNC System	Siemens 840Dsl	Siemens 840Dsl	■ Application method
Max. module (mm)	4	10	1. Spiral bevel Gear - Completing Method (G-mode & Free-mode) - Generating Method (G-mode)
Max. transmission ratio	10 : 1	10 : 1	2. Stright bevel Gear - Up-Low Position Method (Free-mode)
Max. face width (mm)	30	50	■ Other options.
Number of teeth 5~100	5~200	5~200	1. Automatic wheel balance device
Max. diameter of workpiece (mm)	200	350	1) Improved Precision; - Reduced Vibration & Enhanced Grinding Quality.
Grinding wheel diameter	2~6 inch	3.5~9 inch	2) Extended Machine Lifespan; - Lower Maintenance Costs.
Speed of Grinding wheel ( RPM )	12,000(stepless)	6000	3) Increased Operational Efficiency - Automation & Convenience. - Enhanced Safety
Workpiece spindle taper	Morse 5#	1:20	2. Automatic fire extinguishing device
Hole diameter of the larger end (mm)	Ø70	Ø100	- Automatic Extinguishing by detecting Smoke, Temperature, and Flames
Workpiece spindle taper hole	1 : 20	1 : 20	
Overall dimensions : L×W×H ( mm )	4100×2600×2800	5000×3600×3500	
Total weight (Kg)	7,000	13,000	



# YH9150 CNC BEVEL GEAR LAPPING MACHINE

5-axis machine with 3-axis linkage



SPECIFICATIONS			YH9150 <sub>20.7</sub>	YH9460
CNC System			Siemens 840Dsl	Siemens 840Dsl
Max. diameter of workpiece (mm)	Gear		500	600
	Pinion		250	260
Y : Pinion spindle nose to gear axis ( mm )			180 ~ 370	165 ~ 360
Z : Gear spindle nose to pinion axis ( mm )			140 ~ 270	140 ~ 290
X : Offset ( mm )			±75	±75
Brake load ( Nm )			0 ~ 27	0 ~ 27
Speed of pinion spindle ( r/min )			0 ~ 3000	0 ~ 2500
Hole diameter of the large end(mm)	Pinion		100	153
	Gear		60	100
Spindle taper	Pinion		1:20	1:20
	Gear		1:20	1:20
Spindle hold	Pinion	Depth of taper hole ( mm )	150	180
	Gear		80	160
Diameter of through Workpiece			Pinion	58
Spindle hole ( mm )			Gear	58
Overall dimensions ( mm )			1900×1680×2240	2500×2700×2400
Net weight ( kg )			6000	8000



# JCMT BEVEL GEAR CUTTER SHARPENER

6-axis machine with 4-axis linkage



SPECIFICATIONS	YH9420	YH9460
	14.2	
CNC System	Siemens 828Dsl	Siemens 828Dsl
Diameter of cutter	1.1" ~ 12"	6.0" ~ 24"
Material of grinding wheel	CBN	CBN
Diameter of grinding wheel (mm)	180	300
Speed of grinding wheel (rpm)	1800 ~ 5000	1800 ~ 5000
Diameter of indexing rotary table (mm)	Φ200	Φ450
Mounting diameter of cutter spindle (mm)	Φ25.4×1/12	Φ58.221×1/12
	Φ58.221×1/24	Φ126.966×1/24
	Φ126.966×1/24	Φ215.8
A Obliquity of worktable	- 90°~40°	- 90°~40°
Power of motor (KW)	2.2	3.7
Dimension ( L×W×H ) (mm)	2070×2300×2100	2000×2650×3000
Weight (Kg)	4,000	4,000

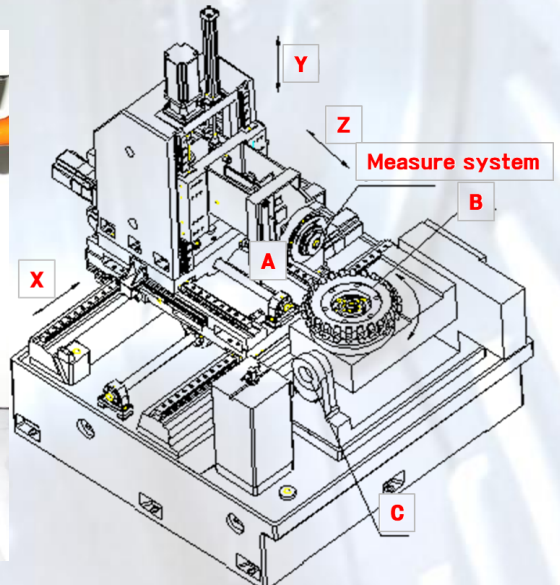
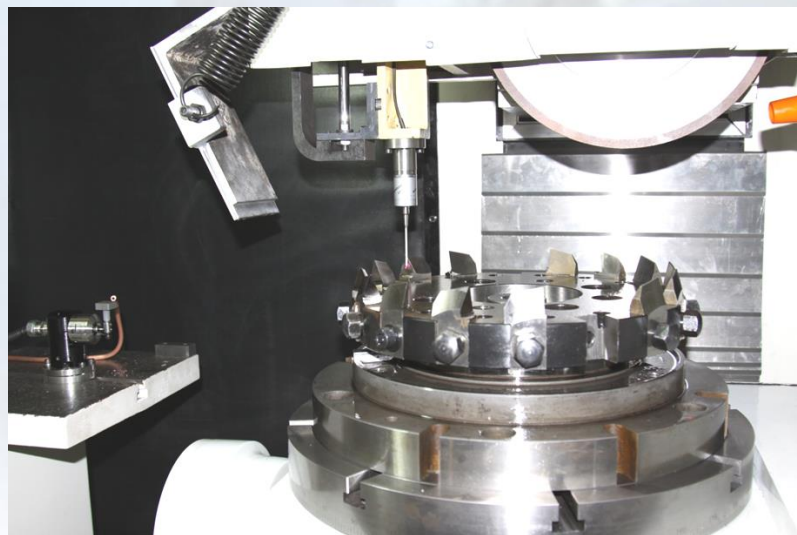



# JCMT BEVEL GEAR CUTTER SHARPENER

11-axis machine with 5-axis linkage



图 4.2 坐标轴的配置

SPECIFICATIONS		YH9330	SIEMENS 9.3 REXROTH 8.9
CNC System		Siemens 828Dsl	
Max.diameter		300 mm	
Min.diameter		50 mm	
Processing range :		Sharp edge of large end and small end	
Workpiece spindle	1) Diameter of spindle straight hole 2) Depth of spindle straight hole	Φ90 mm	15 mm
Motorized spindle	1) Max. diameter of cutter holder 2) Power of motorized spindle 3) Speed of motorized spindle	Φ16 mm	1.1 KW 6000r/min
Drive spindle torque	1) X1 , X2—servo motor of horizontal movement 2) Y1 , Y2—servo motor of vertical movement 3) A—torque motor of workpiece spindle indexing	8 Nm	8 Nm 12 Nm
Overall dimension ( L×W×H )		2300×1650×2350 mm	
Weight about		3000 kg	



MEMO:

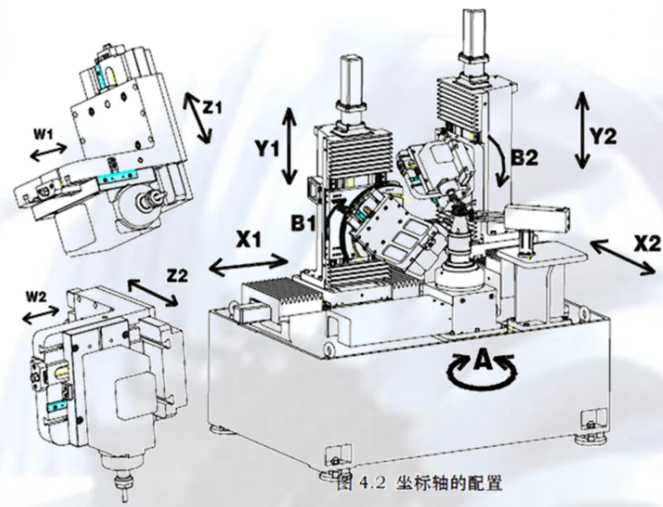
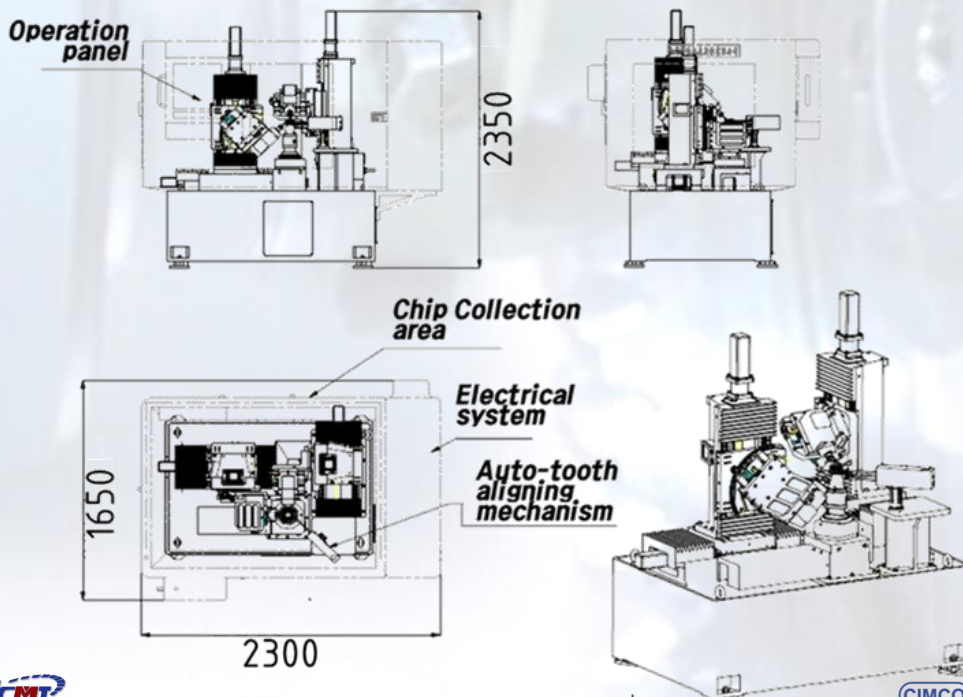

精诚机床  
JING CHENG MACHINE TOOL

## 代理授权书 certificate of authorization

兹授权 CHANG IL MACHINERY CO., LTD 为 TIANJIN JINGCHENG MACHINE TOOL CO., LTD (JCMT) 在韩国地区独家代理。

This document certifies that CHANG IL MACHINERY CO., LTD has been appointed as TIANJIN JINGCHENG MACHINE TOOL CO., LTD (JCMT) 's exclusive agent in Korea.

独家权的详细内容如下：兹授予 CHANG IL MACHINERY CO., LTD 在韩国市场销售推广和提供由 JCMT 开发和量产的所有锥齿轮相关的机械和设备的售后服务的权利。

The details of the exclusive rights are as follows: CHANG IL MACHINERY CO., LTD is hereby granted the authority to be responsible for the sales promotion activities and after-sales service for all bevel gear-related machines and equipment developed and mass-produced by JCMT in the Korean market.

代理地区：仅限韩国

Territory: In Korea only

有效期：2023.12.01~2028.12.01

Authorized period : 01<sup>st</sup> DEC 2023~ 01<sup>st</sup> DEC 2028

天津精诚机床股份有限公司  
TIANJIN JINGCHENG MACHINE TOOL CO.,LTD





**MEMO:**



**MEMO:**





**MEMO:**





**CIMCO**<sup>®</sup>

**昌溢精工(株)**

CHANG IL MACHINERY CO.,LTD

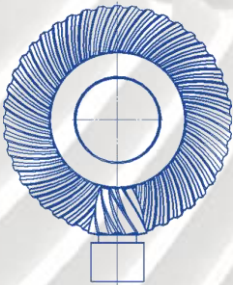

**CIMCO** CHANG IL MACHINERY CO.,LTD

**Overseas sales corporation**

**Office Add: Youwon O/T rm 1419.**

**27, Seomyeonmunhwa-ro, Busanjin-gu,  
Busan, Republic of Korea**

**E-mail: [cimcotools@naver.com](mailto:cimcotools@naver.com)**

**Phone: +82 51 807-4825**

**FAX: +82 503-8379-4067**

**Instagram: [cimcotools](https://www.instagram.com/cimcotools)**